

**PHILIPS**

AC2958  
AC2959



# User manual



# Contents

<b>1</b>	<b>Your air purifier</b> .....	<b>2</b>
	Product overview .....	2
	Controls overview .....	3
<b>2</b>	<b>Getting started</b> .....	<b>3</b>
	Installing the filter .....	3
	Wi-Fi indicator .....	4
	Wi-Fi connection .....	4
<b>3</b>	<b>Using the air purifier</b> .....	<b>4</b>
	Air quality light .....	4
	Turning On and Off .....	5
	Changing the mode setting .....	6
	Switching the display indicator .....	7
	Using the light on/off function .....	7
	Checking the filter status .....	8
<b>4</b>	<b>Cleaning and maintenance</b> .....	<b>8</b>
	Cleaning the body of the air purifier .....	8
	Cleaning the particle sensor .....	8
	Cleaning the surface of the filter .....	9
	Replacing the filter .....	10
	Filter reset .....	11
<b>5</b>	<b>Storage</b> .....	<b>11</b>
<b>6</b>	<b>Troubleshooting</b> .....	<b>12</b>

# 1 Your air purifier

Congratulations on your purchase, and welcome to Philips!

To fully benefit from the support that Philips offers, register your product at [Philips.co.in/welcome](https://philips.co.in/welcome).

---

## Product overview

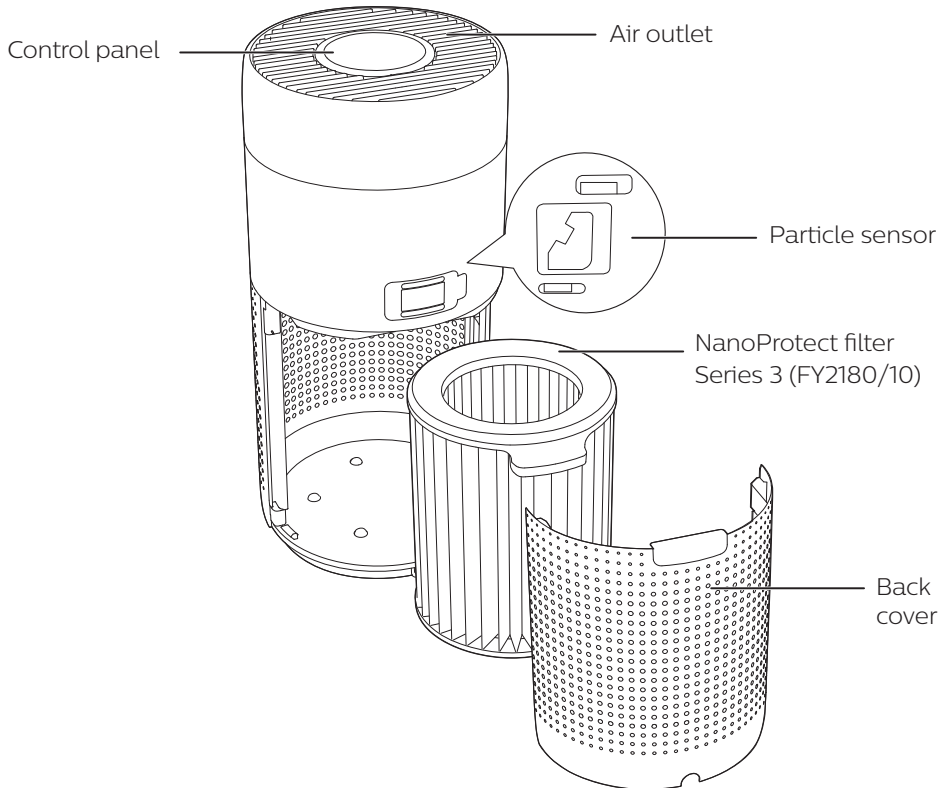

## Controls overview

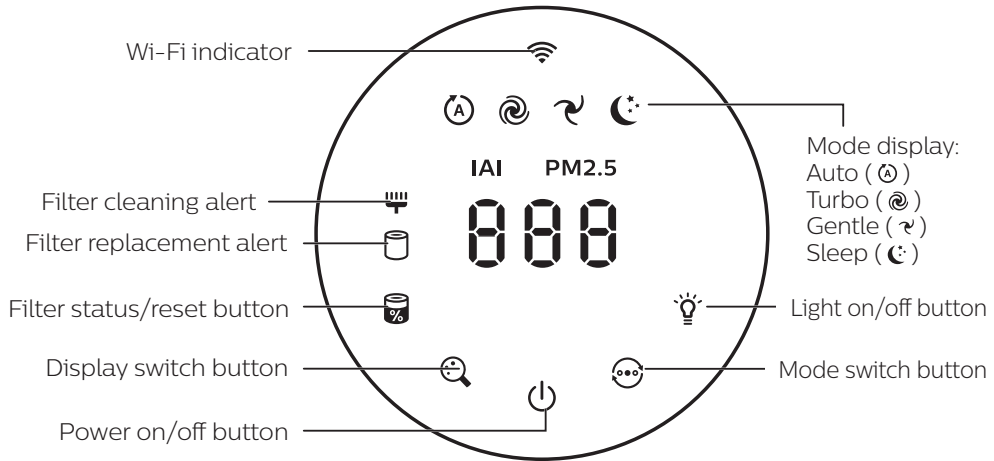

## 2 Getting started

### Installing the filter

**Note:** Make sure the air purifier is unplugged from the electrical outlet before installing the filter.

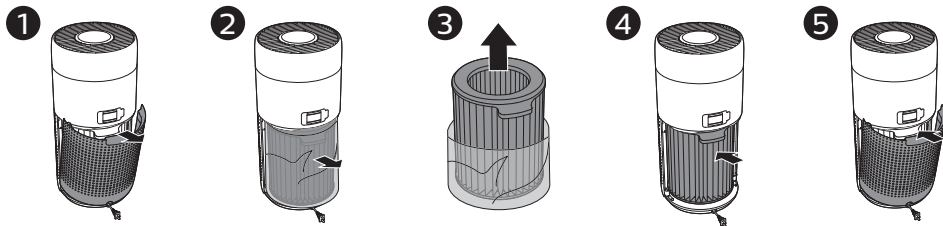

- 1 Pull the back cover and remove it from the appliance.
- 2 Pull the filter from the appliance.
- 3 Remove all packaging materials of the air purification filter.
- 4 Put the filter back into the appliance.
- 5 Reattach the back cover.

---

## Wi-Fi indicator

Wi-Fi icon status	Wi-Fi connection status
Blink in orange	Connecting to the smartphone
Blink in white	Connecting to the router
Stable in white	Connected to the router
Off	Wi-Fi function disabled

---

## Wi-Fi connection

---



### First time connection

- 1 Download and install the Philips “Clean Home+” app from the **App Store** or **Google Play**.
- 2 Connect your smartphone or tablet to your Wi-Fi network.
- 3 Launch the “Clean Home+” app and click on “**Connect a New Device**” or press the “+” button on the top of the screen. Follow the onscreen instructions to connect the air purifier to your network.



---

### Reset the Wi-Fi connection

- 1 Touch  and  for 3 seconds until you hear a beep.  
↳ The Wi-Fi indicator  blinks orange.
- 2 Follow the steps 3 in “**First time connection**” section.

**Note:** Please check [www.philips.com/cleanhome](http://www.philips.com/cleanhome) for the latest update of supported Operation System and devices.

---

## 3 Using the air purifier

---

### Air quality light

After approximately 30 seconds, the particle sensor selects the color that corresponds to the surrounding air quality of airborne particles.

**Note:** The color of the air quality light is determined by the highest risk index among PM2.5, IAQ and readings.

**PM2.5** refers to airborne particle pollutants smaller than 2.5 micrometers.

PM2.5 level	Air quality light color	Air quality level
≤60	Blue	Good
61-120	Blue-purple	Fair
121-250	Purple-red	Poor
>250	Red	Very poor

**IAI** refers to the level of indoor air allergen.

IAI level	Air quality light color	Air quality level
1-3	Blue	Good
4-6	Blue-purple	Fair
7-9	Purple-red	Poor
10-12	Red	Very poor

---

## Turning On and Off

**Note:**

- Put the plug of the air purifier in the power socket.
- If the purifier stays connected to the electrical outlet after turning OFF, the air purifier will operate under the previous settings when turned ON again.

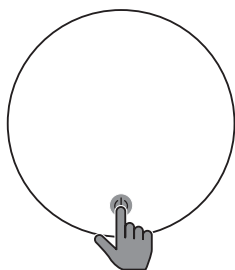

- Touch  to switch on the air purifier.

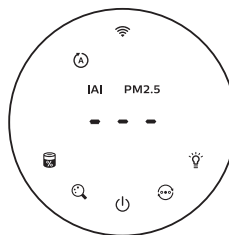

- The “---” displays on the screen during warming up. Then the air purifier shows the PM2.5/IAI level after measuring the air quality.



- The air purifier operates in the auto mode with PM2.5 displayed on the screen.

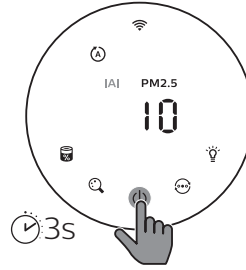

- Touch and hold the  button for 3 seconds to switch off the air purifier.

---

## Changing the mode setting

You can choose Auto mode, Turbo mode, Gentle mode or the Sleep mode by touching the  button.

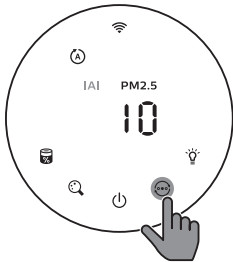

**Auto mode (A):** The air purifier automatically adjusts the fan speed in accordance with the ambient air quality.

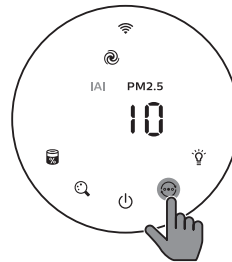

**Turbo mode (⊙):** The air purifier operates on the highest speed.

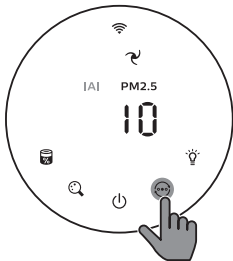

**Gentle mode (⌚):** The air purifier operates at a low speed.

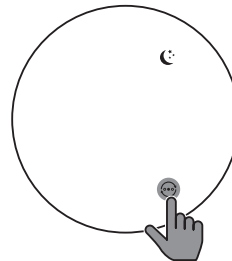

**Sleep mode (☾):** The air purifier operates quietly at a low speed. After 3 seconds, the screen lights off.



---

## Switching the display indicator

### Note:

- The appliance display PM2.5 level by default.

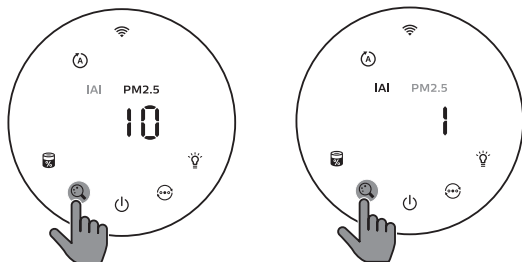

---

## Using the light on/off function

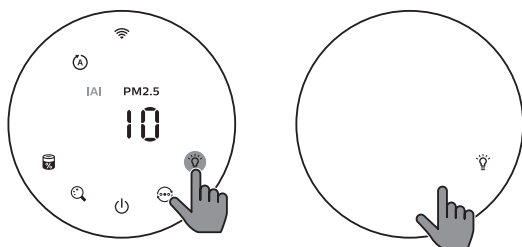

You can touch the light on/off button  manually to turn off all lights and the control panel. Touch any button to wake up all lights.

### With the light sensor:

- The control panel can automatically turn on, turn off or dim according to the ambient light.
- The control panel will be off or dim when the ambient light is dark.

You can touch any button to wake up all lights. If no further operation, all lights will be off or dim again to match with the ambient light.

## Checking the filter status

- Touch the filter status check/reset  button to check the filter service life status.

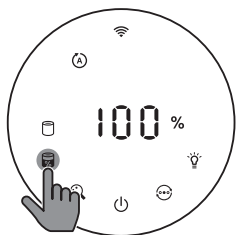

Icon color	Display (%)
Blue	16-100
Blue-purple	9-15
Purple-red	4-8
Red	0-3

**Note:** The appliance goes back to normal display if no operations after 3 seconds.

## 4 Cleaning and maintenance

**Note:**

- Do not attempt to clean the particle sensor with a vacuum cleaner.
- Switch off the air purifier and unplug from the power socket before following action.

### Cleaning the body of the air purifier

Use a soft, dry cloth to clean both the interior and exterior of the air purifier and the air outlet.

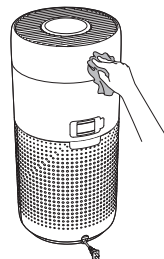

### Cleaning the particle sensor

Clean the particle sensor every 2 months for optimal functioning of the appliance.

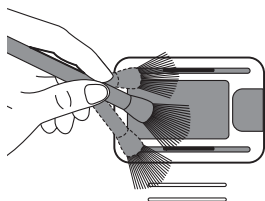

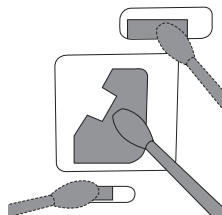

- 1 Clean the particle sensor inlet and outlet with a soft brush.

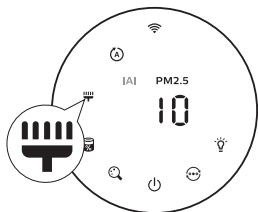

- 2 Clean the particle sensor with a damp cotton swab. Dry all parts thoroughly with a dry cotton swab.

## Cleaning the surface of the filter



Clean the surface of filter with vacuum cleaner when the filter cleaning alert  display on the screen.



1 Pull the back cover and remove it from the appliance.

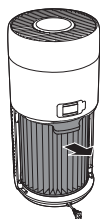

2 Pull the filter from the appliance.

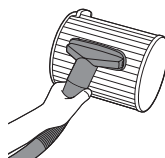

3 Clean the surface of the filter with a vacuum cleaner.



4 Put the filter back into the appliance.

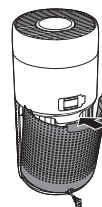

5 Reattach the back cover.

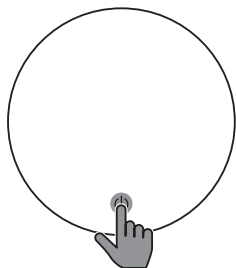

6 Touch the  button to switch on the appliance.

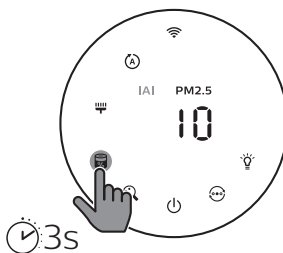

7 Touch and hold the filter status check/reset button  for 3 seconds to reset the filter cleaning time.

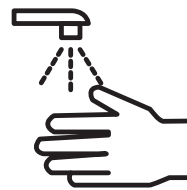

8 Wash your hands thoroughly after cleaning the filter.

## Replacing the filter

### Note:

- The filter is not washable or reusable.
- Do not smell the filter as it has collected pollutants from the air.

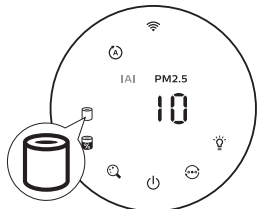

When the filter need to be replaced, the filter replacement alert  lights up red.

- 1 Replace the filter with Philips NanoProtect filter Series 3 (FY2180/10) , Please follow the step of Chapter “Installing the filter”.

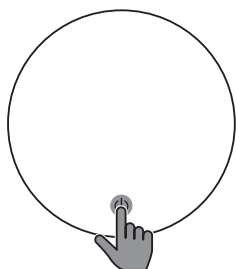

- 2 Touch the  button to switch on the appliance.



- 3 Touch and hold the filter status check/ reset button  for 3 seconds to reset the filter replacement time.

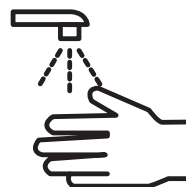

- 4 Wash your hands thoroughly after replacing the filter.

## Filter reset

You can also replace the filter before filter replacement alert (  ) displays on the screen. After replacing a filter, you need to reset the filter lifetime counter manually.

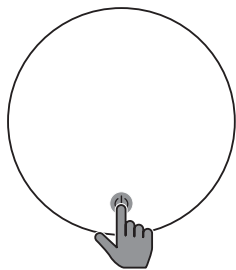

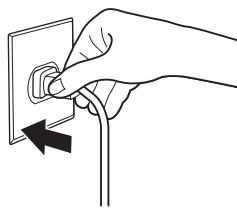

- 1 Touch the power  button for 3 seconds to turn off the appliance and unplug from power socket.

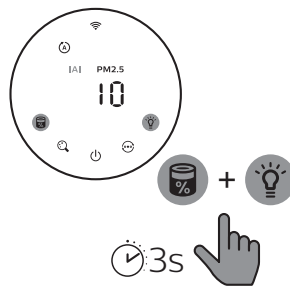

- 2 Put the power plug in the power socket.



- 3 Within 15 seconds after power on, touch and hold  and  button for 3 seconds to reset the filter lifetime counter.

## 5 Storage

- 1 Turn off the air purifier and unplug from the power socket.
- 2 Clean the air purifier, particle sensor and the surface of the filter (see the chapter “Cleaning and maintenance”).
- 3 Let all parts air dry thoroughly before storing.
- 4 Wrap the filter in air tight plastic bags.
- 5 Store the air purifier, filter in a cool, dry location.
- 6 Always thoroughly wash hands after handling filters.

## 6 Troubleshooting

This chapter summarizes the most common problems you could encounter with the appliance. If you are unable to solve the problem with the information below, contact the Consumer Care Center in your country.

Problem	Possible solution
The appliance does not work properly.	<ul style="list-style-type: none"><li>• The filter replacement alert has been on continuously but you have not replaced the corresponding filter. As a result, the appliance is now locked. In this case, replace the filter and long press  to reset the filter lifetime counter.</li></ul>
The airflow that comes out of the air outlet is significantly weaker than before.	<ul style="list-style-type: none"><li>• The surface of the filter is dirty. Clean the surface of the filter (see the chapter “Cleaning and maintenance”).</li></ul>
The air quality does not improve, even though the appliance has been operating for a long time.	<ul style="list-style-type: none"><li>• Check if the packing material is removed from the filter.</li><li>• The filter has not been placed in the appliance. Make sure that the filter (FY2180/10) is properly installed.</li><li>• The particle sensor is wet. The humidity level in your room is high and causes condensation. Make sure that the particle sensor is clean and dry (see the chapter “Cleaning and maintenance”).</li><li>• Room size is large or the outdoor air quality is poor. For optimum purification performance, please close the doors and windows when operating the air purifier.</li><li>• There are indoor pollution resources. For instances, smoking, cooking, incense, perfume or alcohol.</li><li>• Filter reaches the end of life. Replace the filter with a new one.</li></ul>
The color of the air quality light always stays the same.	<ul style="list-style-type: none"><li>• The particle sensor is dirty. Clean the particle sensor (see the chapter “Cleaning and maintenance”).</li></ul>

Problem	Possible solution
The appliance produces a strange smell.	<ul style="list-style-type: none"> <li>• The first few times you use the appliance, it may produce a plastic smell. This is normal. However, if the appliance produces a burnt smell even if removing filters, contact your Philips dealer or an authorized Philips service center. The filter may produce smell after being used for a while because of the absorption of indoor gases. It's recommended that you reactivate the filter by putting it in direct sunlight for repeated use. If odor still exists, replace the filter.</li> </ul>
The appliance is extra loud.	<ul style="list-style-type: none"> <li>• It's normal if the appliance runs at the Turbo mode.</li> <li>• In the Auto mode, if the appliance is too loud, maybe the appliance runs at high speed because air quality becomes worse, or your personalized setting in App triggers a higher fan speed. You can choose the Sleep mode, or change the settings in the app.</li> <li>• If anything drops into air outlet, it may also cause abnormal loud sound. Immediate turn off appliance, turn appliance upside down, to get foreign objectives out of appliance.</li> <li>• If there is abnormal sound, contact the Consumer Care Center in your country.</li> </ul>
The appliance still indicates that I need to replace a filter, but I already did.	<ul style="list-style-type: none"> <li>• Perhaps you did not reset the filter lifetime counter. Switch on the appliance. Then touch and hold the reset button () for 3 seconds.</li> </ul>
Error code "E1" displays on the screen.	<ul style="list-style-type: none"> <li>• The motor has malfunctions. Contact the Consumer Care Center in your country.</li> </ul>

Problem	Possible solution
The Wi-Fi setup is not successful.	<ul style="list-style-type: none"> <li>• If the router your purifier is connected to is dual – band and currently it is not connecting to a 2.4GHz network, please switch to another band of the same router (2.4GHz) and try to pair your purifier again. 5GHz networks are not supported. If your purifier is connected to a dual – band router, please switch to the 2.4GHz network of the router and try to pair your purifier again.</li> <li>• Web authentication networks are not supported. Public Wi-Fi such as office or hotel networks are not supported.</li> <li>• Check if the purifier is within range of the Wi-Fi router. You can try to locate the air purifier closer to the Wi-Fi router.</li> <li>• Check if the Wi-Fi password is correct. The password is case-sensitive.</li> <li>• Retry the setup with the instructions in section “Reset the Wi-Fi connection”.</li> <li>• Keep the appliance away from other electronic devices that may cause interferences.</li> <li>• Check if the mobile device is in airplane mode. Make sure to have the airplane mode deactivated when connecting to the Wi-Fi network.</li> <li>• If the Wi-Fi pairing fails after trying several times, please turn off the cellular data on your smartphone in the Settings section and start the pairing again.</li> <li>• If the Wi-Fi icon on your purifier’s display is in stable white but without seeing the purifier in your app, click on “Connect a New Device” and add the purifier from the local list on “Begin setup” page.</li> <li>• Consult the help section in the app for extensive and up-to-date troubleshooting tips.</li> </ul>











© 2020 Koninklijke Philips N.V.  
All rights reserved  
3000 050 55592

